

**FEATURES/BENEFITS**

The Series SD dual-phase relays are designed for all types of loads. The design incorporates two relays in a single package. The relays utilize optical isolation to protect the control from load transients. High-current models are excellent for motor and phase angle control. The 50A 600 Vac models are available with common control connector or individual control connector. Applications include motor control, heating control, uninterruptible power supplies, light dimmers, industrial and process control, and on/off controls of AC equipment. UL recognized. UL File Number: E1285555.

- Designed for all types of loads
- Dual output (two relays in one package)
- Faston terminals
- Connector for common or individual control
- Tight zero-cross window for low EMI
- High immunity to surges



Part Number	Description
SD24R50-06	12-280 Vac
SD24R50	12-280 Vac
SD24D40-06	12-280 Vac
SD24R40-06	12-280 Vac
SD24D50-06	12-280 Vac
SD48D40-06	24-500 Vac
SD48D50A	24-600 Vac
SD48D50A2	24-600 Vac

**Part Number Explanation**

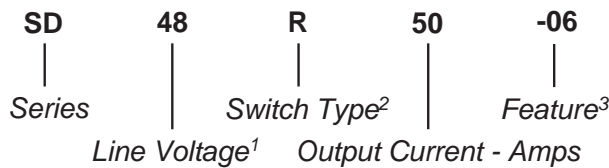

**NOTES**

- 1) Line Voltage (nominal): 24 = 240 Vac; 48 = 480 Vac
- 2) Switch Type: R = Random turn-on; D = Zero-cross turn-on;
- 3) Features: -06 = Faston terminals  
A = Common control adapter  
A2 = Individual control adapter

**INPUT (CONTROL) SPECIFICATION**

	Min	Max	Units
<b>Control Range</b>			
SD24	4	30	Vdc
SD48D40-06	5	30	Vdc
SD48D50XX	10	30	Vdc

**Input Current Range**

All relays (See Fig. 4a)	3		mA
--------------------------	---	--	----

**Must Turn-Off Voltage**

All relays	1		Vdc
------------	---	--	-----

**Input Resistance (Typical)**

SD24	1000	Ohms
SD48D40-06	1000	Ohms
SD48D50A	1400	Ohms
SD48D50A2	1800	Ohms

**Reverse Voltage Protection**

All relays	30		V
------------	----	--	---

**BLOCK DIAGRAM**

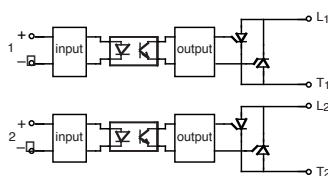

Figure 1a — All SD relays except SD48D40-06

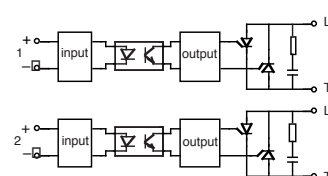

Figure 1b — SD48D40-06

MECHANICAL SPECIFICATION

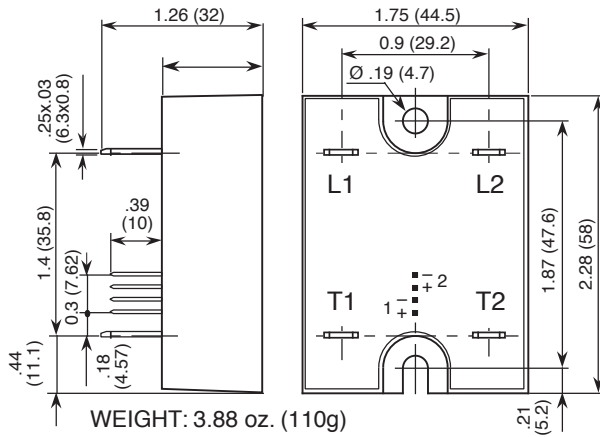

Figure 2a — SD24R50-06, and SD24D50-06; dimensions in inches (mm)

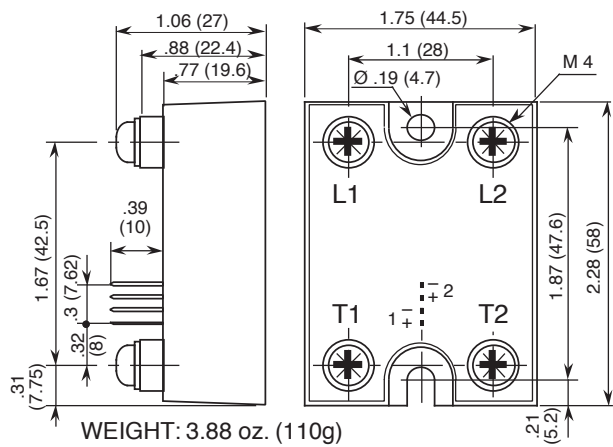

Figure 2b — SD24R50; dimensions in inches (mm)

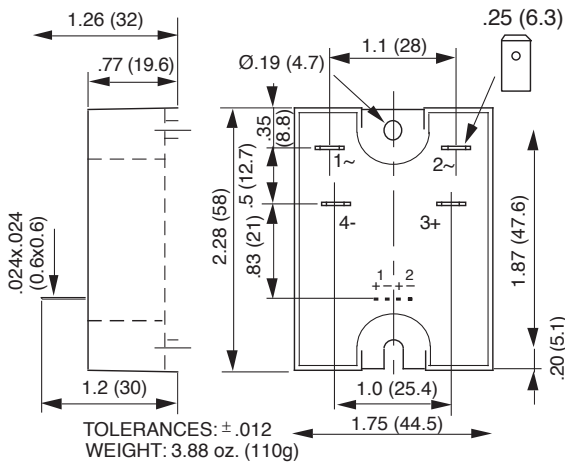

Figure 2c — SD48D40-06, SD24D40-06 and SD24R40-06; dimensions in inches (mm)

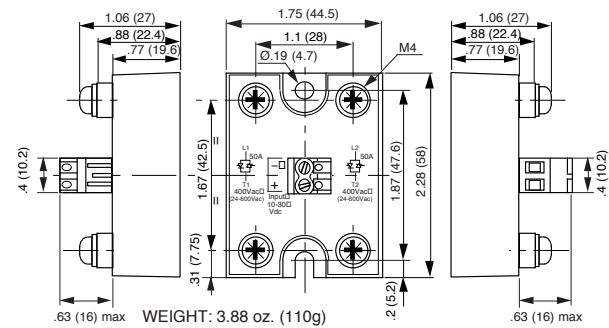

Figure 2d — SD48D50A; dimensions in inches (mm)

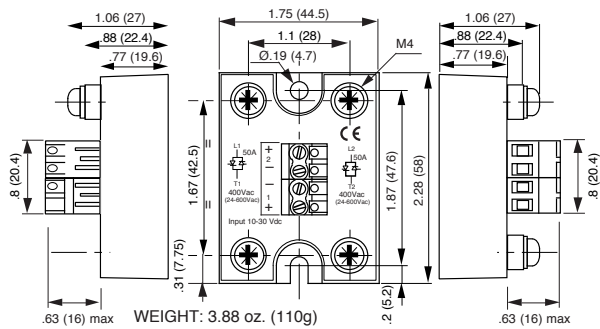

Figure 2e — SD48D50A2; dimensions in inches (mm)

TYPICAL APPLICATION

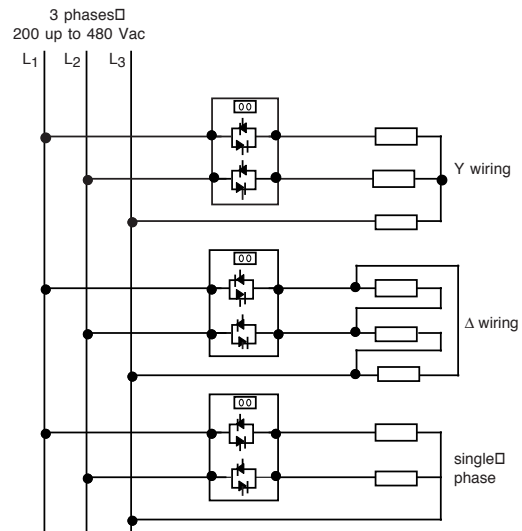

Figure 3 — SD48D50A

OUTPUT (LOAD) SPECIFICATION				
Input Type	Min	Max	Units	
<b>Operating Range</b>				
SD24	R/D	12	280	Vrms
SD48D40-06		24	510	Vrms
SD48D50XX		24	600	Vrms
<b>Peak Voltage</b>				
SD24			600	Vpeak
SD48			1200	Vpeak
<b>Load Current Range (Resistive)</b>				
SD24D40-06, SD24R40-06 & SD48D40-06				
		.005	40	Arms
All other relays		.005	50	Arms
<b>Maximum Surge Current Rating (Non-Repetitive)</b>				
SD24D40-06, SD24R40-06, & SD48D40-06				
			350	A
All other relays			550	A
<b>On-State Voltage Drop</b>				
All relays output current			1.6	V
<b>Zero-Cross Window</b>				
SD	R		NA	
SD	D/A		±12	Vac
<b>Off-State Leakage Current (60Hz)</b>				
SD48D40-06			2.5	mA
All other relays			1	mA
<b>Turn-On Time (60 Hz)</b>				
SD24	R		0.1	ms
All other relays			8.3	ms
<b>Turn-Off Time (60 Hz)</b>				
All relays			8.3	ms
SD24R40-06			10	ms

Input Type	Min	Max	Units
<b>Off-State dv/dt</b>			
All relays		500	V/μs
<b>Maximum di/dt (Non-Repetitive)</b>			
All relays		50	A/μs
<b>Operating Frequency Range</b>			
All relays	10	440	Hz
<b>I<sup>2</sup>t for Match Fusing (&lt;8.3ms)</b>			
SD24D40-06, SD24R40-06 & SD48D40-06			612 A <sup>2</sup> S
All other relays			1500 A <sup>2</sup> S

OUTPUT (LOAD) SPECIFICATION (Continued)

**CONTROL CHARACTERISTICS**

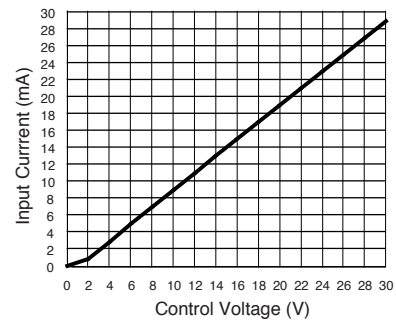

Figure 4a — SD24 and SD48D40-06 relays

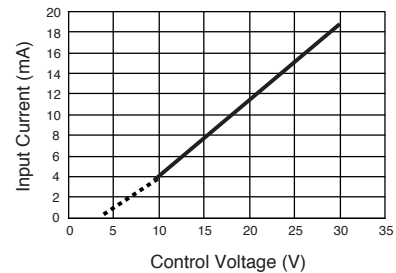

Figure 4b — SD48D50A relay

**ENVIRONMENTAL SPECIFICATION**

	Min	Max	Units
Operating Temperature	-40	100	°C
Storage Temperature	-40	100	°C

**Input-Output Isolation**

SD24D40-06, SD24R40-06 & SD48D40-06

	4000	Vrms
All other relays	3300	Vrms

**Output-Case Isolation**

SD24D40-06, SD24R40-06 & SD48D40-06

	2500	Vrms
All other relays	3300	Vrms

**Output to Output**

SD48D50XX	3300	Vrms
All other relays	2500	Vrms

**Junction-Case Thermal Resistance**

SD24D40-06, SD24R40-06 & SD48D40-06

	1.1	°C/W
All other relays	0.5	°C/W

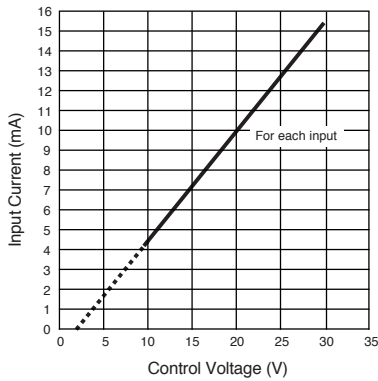

Figure 4c — SD48D50A2 relay

**SURGE CURRENT**

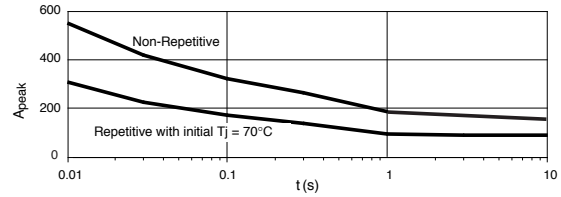

Figure 5a — SD24 50A output current

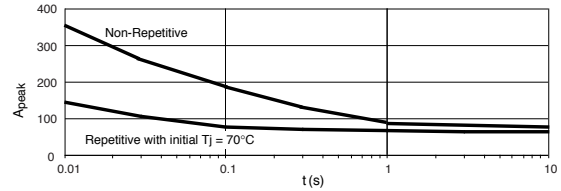

Figure 5b — SD48 40A and SD24 40A output current

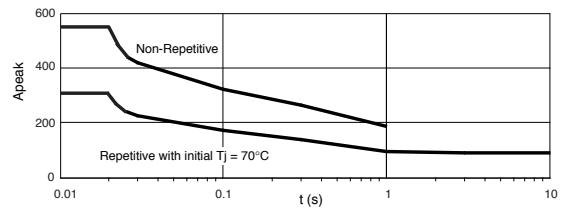

Figure 5c — SD48 50A output current

**NOTES:**

1. Electrical specifications at 25°C unless otherwise specified.
2. For 800Hz applications, contact factory.
3. For additional/custom applications, contact factory.

**THERMAL CHARACTERISTICS**

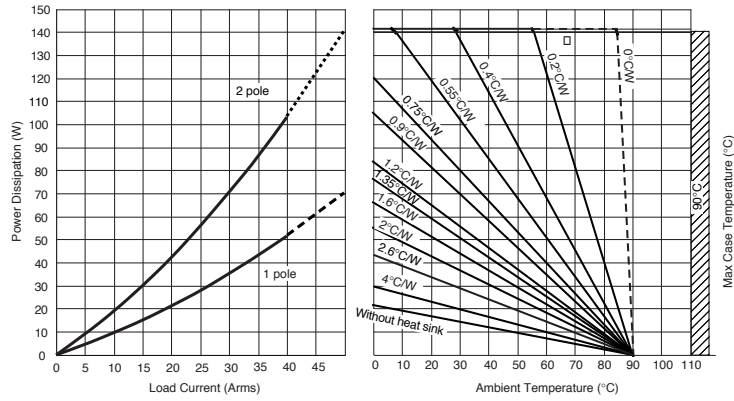

Figure 6a — SD24 50A relays output current

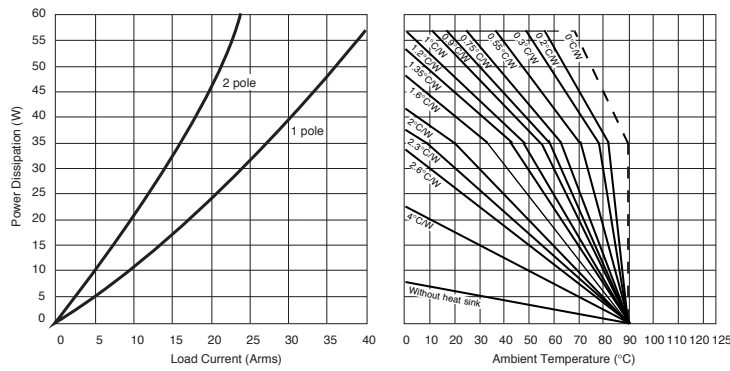

Figure 6b — SD48 40A and SD24 40A output current

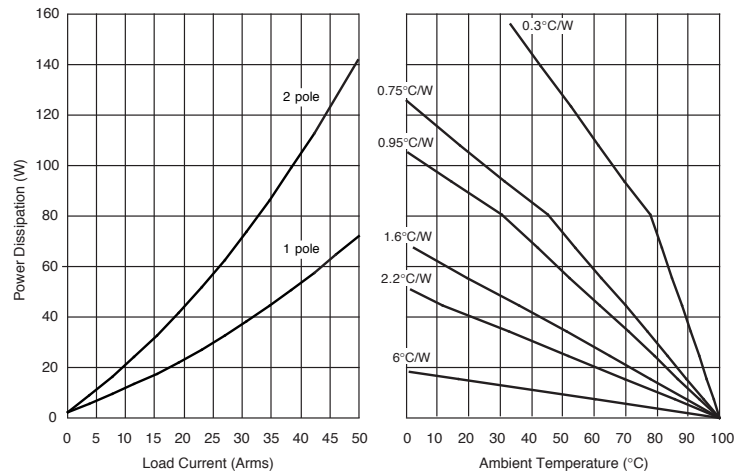

Figure 6c — SD48D50A and SD48D50A2 output current

**OPTIONAL ADD-ONS**

Please order add-ons separately:

- -12 — Thermal pad installed.
- -14 — Plastic touch-proof cover.