



**DETAIL SPECIFICATION FOR  
HIREL 114 RELAYS**



**RELAYS, HIGH RELIABILITY,  
ELECTROMECHANICAL, NON-LATCHING,  
DPDT,  
LOW LEVEL TO 1.0 AMPERE,  
WITH OPTIONAL DIODE(S) FOR  
COIL TRANSIENT SUPPRESSION AND  
POLARITY REVERSAL PROTECTION,  
TERMINALS 0.100 INCH GRID PATTERN**

**TR-HIREL-1/114**

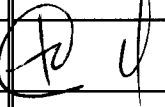
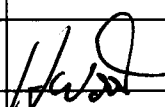

**ISSUE 1**

**27 Feb 2001**

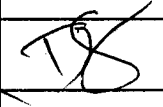
Issue or Amendment No.	Date of Issue	Approved by			
		Engineering	Operations	Product Assurance	Marketing
Issue 1	27 Feb 2001				

**TABLE OF CONTENTS.**

<b>1.</b>	<b>SCOPE .....</b>	<b>5</b>
<b>2.</b>	<b>RELAY CHARACTERISTICS.....</b>	<b>6</b>
2.1.	<b>GENERAL DATA.....</b>	<b>6</b>
2.1.1.	<i>Contact arrangement.....</i>	<i>6</i>
2.1.2.	<i>Temperature range.....</i>	<i>6</i>
2.1.3.	<i>Dimensions and configuration.....</i>	<i>6</i>
2.1.4.	<i>Weight.....</i>	<i>6</i>
2.1.5.	<i>Seal.....</i>	<i>6</i>
2.1.6.	<i>Finish of the terminals.....</i>	<i>6</i>
2.2.	<b>PART NUMBER (ORDERING INFORMATION).....</b>	<b>7</b>
2.3.	<b>CONTACT DATA.....</b>	<b>8</b>
2.3.1.	<i>Contact load and life ratings.....</i>	<i>8</i>
2.3.2.	<i>Static contact resistance or voltage drop.....</i>	<i>8</i>
2.3.3.	<i>Contact bounce time (when specified, see TR-HIREL-1/Supplement 1).....</i>	<i>8</i>
2.3.4.	<i>Contact stabilization time (when specified, see TR-HIREL-1/Supplement 1).....</i>	<i>8</i>
2.4.	<b>ELECTRICAL DATA.....</b>	<b>10</b>
2.4.1.	<i>Insulation resistance.....</i>	<i>10</i>
2.4.2.	<i>Dielectric withstanding voltage.....</i>	<i>10</i>
2.4.3.	<i>Coil data and operating characteristics.....</i>	<i>11</i>
2.4.4.	<i>Timing (over the temperature range).....</i>	<i>11</i>
2.4.5.	<i>Diode characteristics.....</i>	<i>11</i>
2.5.	<b>MOUNTING VARIANTS.....</b>	<b>14</b>
2.6.	<b>TERMINATION VARIANTS.....</b>	<b>15</b>
2.7.	<b>TESTING SELECTION ID DESIGNATOR.....</b>	<b>16</b>
2.7.1.	<i>Manufacturing Variants.....</i>	<i>16</i>
2.7.2.	<i>Screening Variants.....</i>	<i>16</i>
2.8.	<b>ENVIRONMENTAL DATA.....</b>	<b>18</b>
<b>3.</b>	<b>MARKING.....</b>	<b>19</b>
<b>4.</b>	<b>QUALITY ASSURANCE.....</b>	<b>19</b>
4.1.	<b>FINAL PRODUCTION TESTS.....</b>	<b>19</b>
4.2.	<b>SCREENING AND ELECTRICAL MEASUREMENTS.....</b>	<b>19</b>
4.3.	<b>LOT ACCEPTANCE TESTS (WHEN SPECIFIED, SEE TR-HIREL-1/SUPPLEMENT 1).....</b>	<b>19</b>
<b>5.</b>	<b>GENERAL NOTES.....</b>	<b>30</b>

**TABLE OF TABLES.**

TABLE 1. CONTACT LOAD AND LIFE RATINGS. ....	8
TABLE 2. STATIC CONTACT RESISTANCE OR VOLTAGE DROP. ....	9
TABLE 3. POINTS OF APPLICATION AND MEASUREMENT FOR INSULATION RESISTANCE AND DIELECTRIC WITHSTANDING VOLTAGE TESTS. ....	10
TABLE 4. COIL DATA AND OPERATING CHARACTERISTICS OF BASIC RELAYS AND OF RELAYS WITH OPTIONAL DIODE FOR COIL TRANSIENT SUPPRESSION. ....	12
TABLE 5. COIL DATA AND OPERATING CHARACTERISTICS OF RELAYS WITH INTERNAL DIODES FOR COIL TRANSIENT SUPPRESSION AND POLARITY REVERSAL PROTECTION. ....	13
TABLE 6. MOUNTING VARIANTS. ....	14
TABLE 7. TERMINATION VARIANTS. ....	15
TABLE 8. MANUFACTURING VARIANTS. ....	16
TABLE 9. SCREENING VARIANTS. ....	17
TABLE 10. ENVIRONMENTAL TESTS. ....	18
TABLE 11. FINAL PRODUCTION TESTS. <u>1</u> /.....	20
TABLE 12. SCREENING AND ELECTRICAL MEASUREMENTS. <u>1</u> /.....	21
TABLE 13. LOT ACCEPTANCE TEST 3. <u>1</u> /.....	23
TABLE 14. LOT ACCEPTANCE TEST 2. <u>1</u> /.....	24
TABLE 15. LOT ACCEPTANCE TEST 1. <u>1</u> /.....	28

**TABLE OF FIGURES.**

FIGURE 1. OUTLINE DIMENSIONS. ....	5
FIGURE 2. TERMINAL LOCATIONS AND CIRCUIT DIAGRAM (BOTTOM VIEW). ....	5
FIGURE 3. GROUND PIN POSITIONS. ....	15

**TABLE OF APPENDICES.**

APPENDIX A. MOUNTING AND TERMINATION VARIANTS. ....	31
APPENDIX B. DOCUMENT CHANGE HISTORY. ....	33

DETAIL SPECIFICATION FOR 114 RELAYS

RELAYS, HIGH RELIABILITY, ELECTROMECHANICAL, NON-LATCHING, DPDT, LOW LEVEL TO 1.0 AMPERE, WITH OPTIONAL DIODE(S) FOR COIL TRANSIENT SUPPRESSION AND POLARITY REVERSAL PROTECTION, TERMINALS 0.100 INCH GRID PATTERN

1. SCOPE

The performance and testing specifications for the above-referenced product are set forth in this detail specification. References to TR-HIREL-1 are to the most recent version thereof; in the event of conflict between this detail specification and TR-HIREL-1, the specifications set forth in this detail specification shall prevail.

Figure 1. Outline dimensions.

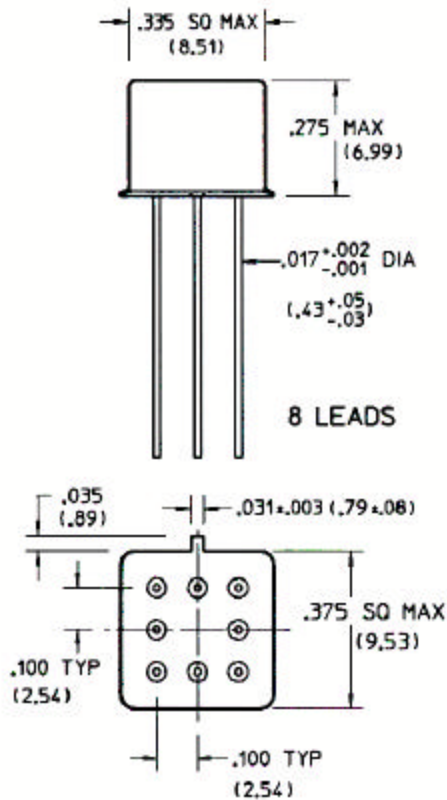
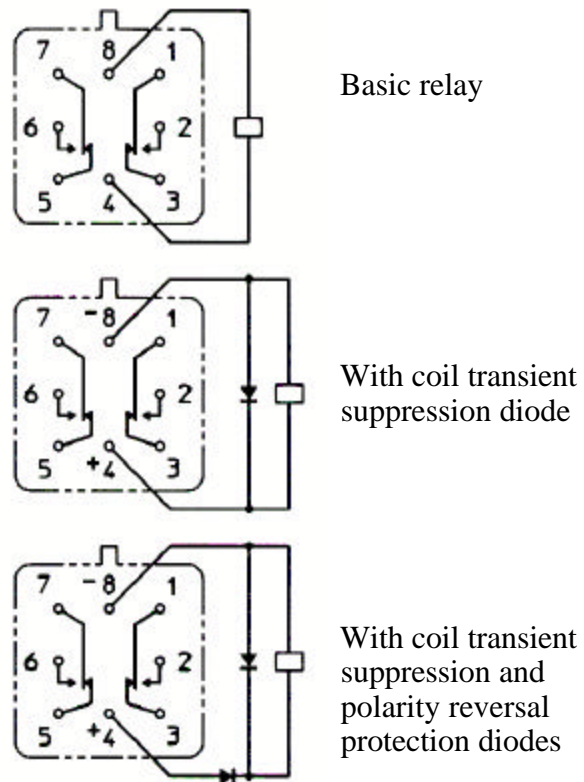

Figure 2. Terminal locations and circuit diagram (bottom view).



Notes to Figures 1 and 2:

1. The standard configuration is shown in Figure 1. See Appendix A herein for mounting and termination variants.
2. Dimensions are in inches. Metric equivalents in mm are given in parentheses.
3. Unless otherwise specified, the tolerance on dimensions is  $\pm 0.010$  in. ( $\pm 0.254$  mm).
4. Circuit diagrams shown in Figure 2 are terminal views (as seen from the bottom of the relays).
5. Terminal numbers are not marked on the relays.

**2. RELAY CHARACTERISTICS****2.1. General Data.****2.1.1. Contact arrangement.**

DPDT (2 Form C).

**2.1.2. Temperature range.**

−65 °C to +125 °C.

**2.1.3. Dimensions and configuration.**

See Figure 1 and Appendix A herein.

**2.1.4. Weight.**

2.55 g (0.09 oz) maximum.

**2.1.5. Seal.**

Hermetic. Leak rate  $1 \times 10^{-8}$  atm-cm<sup>3</sup>/s of air maximum.

**2.1.6. Finish of the terminals.**

Gold plated or solder coated (see Appendix A herein and TR-HIREL-1/Supplement 1).

**2.2. Part Number (ordering information).**

See TR-HIREL-1/Supplement 1 for checklist to be used for procurement.

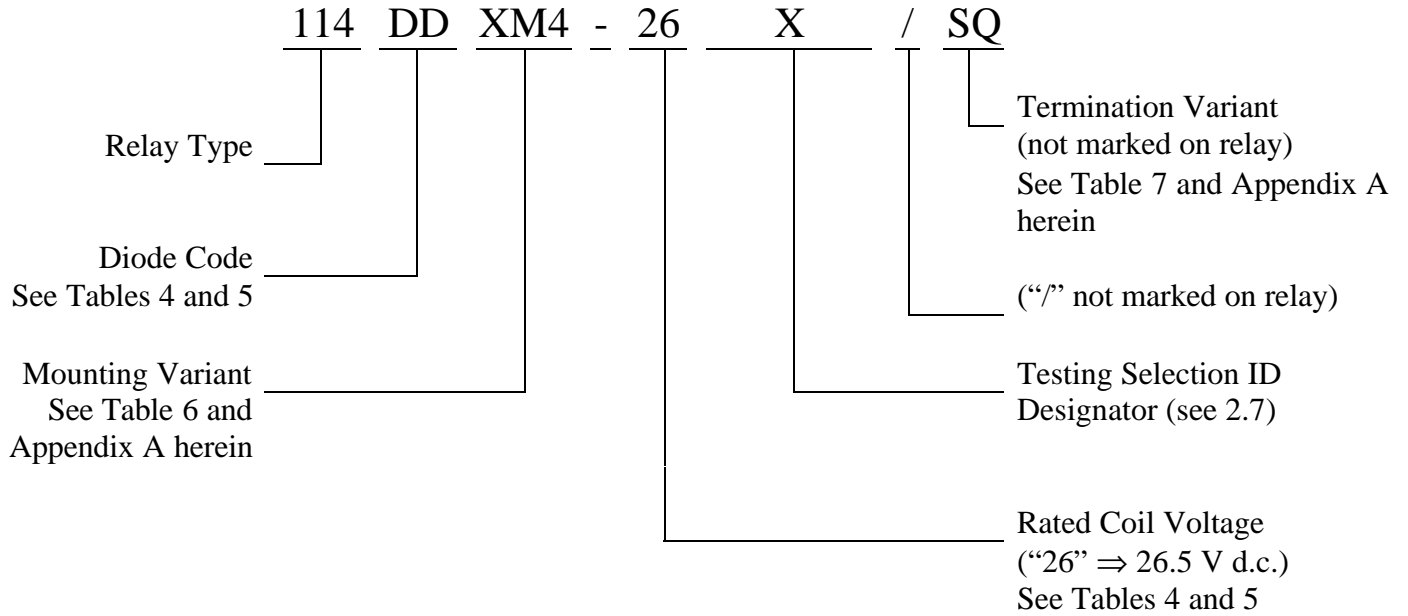

**2.3. Contact Data.**
**2.3.1. Contact load and life ratings.**

See Table 1.

**2.3.2. Static contact resistance or voltage drop.**

 See Table 2. Contact resistance measurements shall be made at approximately  $\frac{1}{8}$  in. from the emergence of the lead from the seating plane of the relay.

**2.3.3. Contact bounce time (when specified, see TR-HIREL-1/Supplement 1).**

1.5 ms maximum.

**2.3.4. Contact stabilization time (when specified, see TR-HIREL-1/Supplement 1).**

2.5 ms maximum.

**Table 1. Contact Load and Life Ratings.**

Load level	Contact load <sup>1/</sup>	Contact life
Low level/Mechanical	10 – 50 $\mu$ A at 10 – 50 mV d.c. or peak a.c.	100,000 cycles rated life
		1,000,000 cycles unmonitored (Mechanical life)
Intermediate current	100 mA at 28 V d.c.	50,000 cycles
High level, resistive	1.0 A at 28 V d.c.	100,000 cycles
High level, inductive	200 mA at 28 V d.c., with 0.32 H inductance	100,000 cycles
High level, lamp	100 mA at 28 V d.c.	100,000 cycles
Overload, resistive	2.0 A at 28 V d.c.	100 cycles

**Notes to Table 1:**  
<sup>1/</sup> Relay case is grounded, unless otherwise specified.

**Table 2. Static Contact Resistance or Voltage Drop.**

Measurement condition		Maximum static contact resistance or voltage drop	
		without attached M4 spacer pad	with M4 spacer pad attached
Initial		0.100 $\Omega$	0.110 $\Omega$
Low level life	during test	33 $\Omega$ (1.65 mV d.c. monitoring level)	
	after 100,000 or 1,000,000 cycle life	0.150 $\Omega$	0.160 $\Omega$
Intermediate current	during test	1 $\Omega$ (100 mV d.c. monitoring level)	
	after 50,000 cycle test	0.200 $\Omega$	0.210 $\Omega$
High level life	during test	voltage drop no more than 5% of open circuit voltage (1.4 V d.c. monitoring level)	
	after 100,000 cycle life	0.200 $\Omega$	0.210 $\Omega$
Overload	during test	not monitored	
	after 100 cycle life	0.200 $\Omega$	0.210 $\Omega$

**2.4. Electrical Data.**
**2.4.1. Insulation resistance.**

Points of measurement are as specified in Table 3. Coil leads of relays supplied with internal diode(s) should be connected together to avoid damage to the diode(s).

10,000 M $\Omega$  minimum at 500 V d.c., except as follows:

1,000 M $\Omega$  minimum at 500 V d.c. between coil and case at +125 °C

1,000 M $\Omega$  minimum at 500 V d.c. after 100 cycle overload,

100,000 cycle high level life, or 50,000 cycle intermediate current tests

**2.4.2. Dielectric withstanding voltage.**

Points of application are as specified in Table 3. Coil leads of relays supplied with internal diode(s) should be connected together to avoid damage to the diode(s).

**2.4.2.1. At atmospheric pressure.**

500 V r.m.s.  $\pm$  5 % at 50 or 60 Hz (as applicable), except as follows:

375 V r.m.s. at 50 or 60 Hz (as applicable) after 100 cycle overload, 100,000 cycle high level life, or 50,000 cycle intermediate current tests

**Table 3. Points of Application and Measurement for Insulation Resistance and Dielectric Withstanding Voltage Tests.**

<b>Points of Application / Measurement</b>	<b>De-energized position</b>	<b>Energized position</b>
Between case, frame, or enclosure, and all contacts	✓	✓
Between case, frame, or enclosure and coil	✓	
Between all contacts and coil	✓	
Between open contacts	✓	✓
Between contact poles	✓	✓

- 2.4.3. **Coil data and operating characteristics.**  
See Tables 4 and 5.
- 2.4.4. **Timing (over the temperature range).**
  - 2.4.4.1. **Operate time.**  
2.0 ms maximum with rated coil voltage.
  - 2.4.4.2. **Release time.**  
1.5 ms maximum from rated coil voltage.
  - 2.4.4.3. **Release time with diode(s).**  
4.0 ms maximum from rated coil voltage.
- 2.4.5. **Diode characteristics.**
  - 2.4.5.1. **Coil transient suppression.**  
1.0 V d.c. maximum negative transient.
  - 2.4.5.2. **Block integrity maximum leakage current.**  
1  $\mu$ A at 50 V d.c.
  - 2.4.5.3. **Breakdown voltage.**  
100 V d.c. minimum at 10  $\mu$ A.

**Table 4. Coil Data and Operating Characteristics of Basic Relays and of Relays with Optional Diode for Coil Transient Suppression.**

Coil voltage (V d.c.) <u>2/</u>		Room ambient temperature (+25 °C)				Over temperature range			Coil transient suppression diode code <u>4/</u>
Rated	Max	Coil resis- tance (W) ± 10 %	Pickup voltage (V d.c.) max <u>3/</u>	Hold voltage (V d.c.) max <u>3/</u>	Dropout voltage (V d.c.) min <u>3/</u>	Pickup voltage (V d.c.) max <u>3/</u>	Hold voltage (V d.c.) max <u>3/</u>	Dropout voltage (V d.c.) min <u>3/</u>	
5.0	5.8	50	2.7	1.4	0.22	3.5	2.3	0.14	D
6.0	8.0	98	3.5	2.0	0.28	4.5	3.2	0.18	D
9.0	12.0	220	5.3	3.0	0.54	6.8	4.9	0.35	D
12.0	16.0	390	7.0	4.0	0.63	9.0	6.5	0.41	D
18.0	24.0	880	10.5	6.0	0.91	13.5	10.0	0.59	D
26.5	32.0	1560	14.2	8.0	1.37	18.0	13.0	0.89	D

**Notes to Table 4:**

1. Each relay possesses high level and low level capabilities. However, relays previously tested or used above 10 mA resistive at 6 V d.c. maximum or peak a.c. open circuit are not recommended for subsequent use in low level applications.
- 2/ The use of any coil voltage other than the rated coil voltage will affect the electrical and dynamic characteristics of the relay.
- 3/ Relay contacts shall transfer to the energized position at a voltage no greater than the maximum pickup voltage, hold in the energized position when the coil voltage is reduced from rated coil voltage to the maximum hold voltage (reference only), and return to the de-energized position at a voltage no less than the minimum dropout voltage.
- 4/ No code letter for relays without diode(s).

**Table 5. Coil Data and Operating Characteristics of Relays with Internal Diodes for Coil Transient Suppression and Polarity Reversal Protection.**

Coil voltage (V d.c.) <u>2/</u>		Room ambient temperature (+25 °C)					Over temperature range			Coil transient suppression and polarity reversal protection diode code	
		Coil resistance (ref. only) (W) <u>3/</u>	Coil circuit current (mA) <u>3/</u>		Pickup voltage (V d.c.) max <u>4/</u>	Hold voltage (V d.c.) max <u>4/</u>	Dropout voltage (V d.c.) min <u>4/</u>	Pickup voltage (V d.c.) max <u>4/</u>	Hold voltage (V d.c.) max <u>4/</u>		Dropout voltage (V d.c.) min <u>4/</u>
Rated	Max		Max	Min							
5.0	5.8	39	128.2	93.2	3.2	2.3	0.60	4.0	2.8	0.60	DD
6.0	8.0	78	78.3	58.3	4.0	2.8	0.70	5.0	3.4	0.70	DD
9.0	12.0	220	42.9	33.0	6.3	4.2	0.90	7.8	5.3	0.80	DD
12.0	16.0	390	32.8	25.6	8.0	5.2	1.10	10.0	6.5	0.90	DD
18.0	24.0	880	22.1	17.5	11.5	7.3	1.40	14.5	10.0	1.10	DD
26.5	32.0	1560	18.5	14.8	15.2	9.5	1.80	19.0	13.0	1.40	DD

**Notes to Table 5:**

1. Each relay possesses high level and low level capabilities. However, relays previously tested or used above 10 mA resistive at 6 V d.c. maximum or peak a.c. open circuit are not recommended for subsequent use in low level applications.
- 2/ The use of any coil voltage other than the rated coil voltage will affect the electrical and dynamic characteristics of the relay.
- 3/ Coil resistance is not directly measurable at relay terminals; coil current shall be measured in lieu of coil resistance.
- 4/ Relay contacts shall transfer to the energized position at a voltage no greater than the maximum pickup voltage, hold in the energized position when the coil voltage is reduced from rated coil voltage to the maximum hold voltage (reference only), and return to the de-energized position at a voltage no less than the minimum dropout voltage.

**2.5. Mounting Variants.**

See Table 6 and Appendix A herein.

**Table 6. Mounting Variants.**

<b>Mounting code</b>	<b>Type of mounting</b>
No Code	Without mounting
Z	Ground pin at position Z
M4	M4 spacer pad
ZM4	Ground pin at position Z with M4 spacer pad
<p><b>Notes to Table 6:</b></p> <ol style="list-style-type: none"> <li>1. Optional ground pins are non-insulated case grounds. See Figure 3 for available ground pin positions.</li> <li>2. 2. M4 spacer pad is a polyester film and is attached to the relay.</li> </ol>	

2.6. Termination Variants.

See Table 7 and Appendix A herein.

Table 7. Termination Variants.

Termination variant	Length of terminals	Finish <sup>1/</sup>
No Code	0.750 in. min. (19.05 mm)	Gold plated or solder coated
G	0.750 in. min. (19.05 mm)	Gold plated
Q	0.750 in. min. (19.05 mm)	Solder coated
S	0.187 ± 0.010 in. (4.75 ± 0.25 mm)	Gold plated or solder coated
SG	0.187 ± 0.010 in. (4.75 ± 0.25 mm)	Gold plated
SQ	0.187 ± 0.010 in. (4.75 ± 0.25 mm)	Solder coated

**Notes to Table 7:**  
<sup>1/</sup> Maximum lead diameter after solder coating is 0.020 in. (0.508 mm), except at the free end of the lead. Maximum lead diameter at the free end of the lead after solder coating is 0.025 in. (0.635 mm).

Figure 3. Ground Pin Positions.

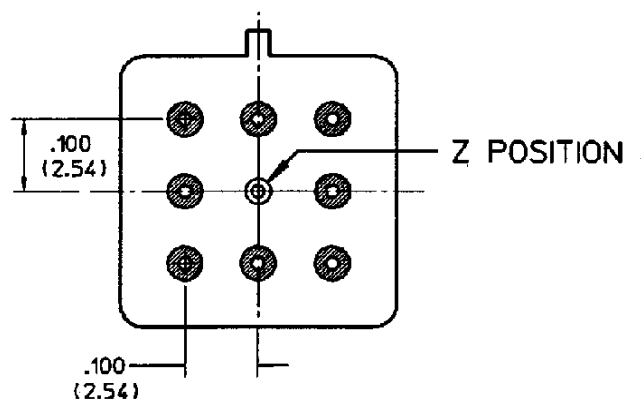

**2.7. Testing Selection ID Designator.**

The Testing Section ID Designator is an alphanumeric field that represents the combination of manufacturing and/or screening variants indicated below that are specified by the Orderer. Each combination of manufacturing and/or screening variants has a unique ID designator which is part of the Part Number (see 2.2). It allows the Orderer to select from specified manufacturing and/or screening variants based on program requirements.

**2.7.1. Manufacturing Variants.**

Prior to encapsulation, when specified (see TR-HIREL-1/Supplement 1), the relays shall be subjected to the tests/inspections specified in Table 8.

**2.7.2. Screening Variants.**

When specified (see TR-HIREL-1/Supplement 1), the relays shall be tested for the following attributes or shall be subjected to the tests/inspections of Table 9 as part of Quality Conformance Inspection. Refer to see TR-HIREL-1/Supplement 1 for a further breakdown of Lot Acceptance Test Level 2 and 1.

**Table 8. Manufacturing Variants.**

<b>Test</b>	<b>Requirement paragraph in TR-HIREL-1</b>	<b>Test method paragraph in TR-HIREL-1</b>
Small Particle Inspection	3.1	4.11.2

**Table 9. Screening Variants.**

<b>Test</b>	<b>Requirement paragraph in TR-HIREL-1</b>	<b>Test method paragraph in TR-HIREL-1</b>
Solderability	3.6.2	4.11.4
Vibration (random)	3.6.6	4.11.11.2
Particle impact noise detection	3.6.21	4.11.23
Contact bounce time	3.4.2.1	4.11.8.5.2
Contact stabilization time	3.4.2.2	4.11.8.5.3
Lot Acceptance Tests (Level 3)	3.1	4.10.3
Lot Acceptance Tests (Level 2)	3.1	4.10.3
Lot Acceptance Tests (Level 1)	3.1	4.10.3

**2.8. Environmental Data.**

The relays shall withstand the environmental tests as specified in Table 10.

**Table 10. Environmental Tests.**

<b>Test</b>	<b>Requirement paragraph in TR-HIREL-1</b>	<b>Test method paragraph in TR-HIREL-1</b>	<b>Details and exceptions</b>
Solderability	3.6.2	4.11.4	
Thermal shock	3.6.4	4.12.9	
Shock (specified pulse)	3.6.5	4.11.10	Test condition B (75 G peak half-sine, 6 ms duration)
Vibration (sinusoidal)	3.6.6	4.12.11.1	
Vibration (random)	3.6.6	4.12.11.2	
Terminal strength	3.6.8	4.11.20	
Coil life	3.6.9	4.11.21	
Resistance to soldering heat	3.6.10	4.11.17	
Salt atmosphere (corrosion)	3.6.11	4.11.13	Performance requirement.
Resistance to solvents	3.6.16	4.11.16	

**3. MARKING**

Marking on the relay includes Teledyne Relays' Part Number (see 2.2), Lot Number, circuit diagram, Teledyne Relays' name, serial number and contact current rating. The circuit diagram as marked on the relay is the terminal view.

**4. QUALITY ASSURANCE**

Quality assurance provisions are as specified in TR-HIREL-1. The following details shall apply:

**4.1. Final Production Tests.**

See Table 11.

**4.2. Screening and Electrical Measurements.**

See Table 12.

**4.3. Lot Acceptance Tests (when specified, see TR-HIREL-1/Supplement 1).**

See Tables 13, 14, 15.

**Table 11. Final Production Tests. 1/**

Inspection	Requirement in TR-HIREL-1	Test method in TR-HIREL-1	Details and exceptions in this spec	Diode Codes		
				None	D	DD
1. Verification of precap inspection, customer source inspection - precap inspection, Marking/serialization	Ref.: 3.6.18, 3.6.17	Ref. 4.11.1.1	2.2, 3.0	✓	✓	✓
2. Verification of small particle inspection (when specified)	3.1	4.11.2	2.7.1	✓	✓	✓
3. Room temperature electrical measurements <u>2/</u>						
a) Coil resistance	3.5.4	4.11.8.2	2.4.3	✓	✓	
b) Coil current	3.5.5	4.11.8.3	2.4.3			✓
c) Insulation resistance	3.5.1	4.11.6	2.4.1	✓	✓	✓
d) Dielectric withstanding voltage (atmospheric pressure)	3.5.2	4.11.7	2.4.2	✓	✓	✓
e) Static contact resistance	3.4.1.1	4.11.8.5.1	2.3.2	✓	✓	✓
f) Pickup voltage	3.5.3.1	4.11.8.1.1	2.4.3	✓	✓	✓
g) Dropout voltage	3.5.3.3	4.11.8.1.3	2.4.3	✓	✓	✓
h) Operate and release time	3.5.6	4.11.8.4	2.4.4	✓	✓	✓
i) Operate and release contact bounce time (when specified)	3.4.2.1	4.11.8.5.2	2.3.3, 2.7.2	✓	✓	✓
j) Operate and release contact stabilization time (when specified)	3.4.2.2	4.11.8.5.3	2.3.4, 2.7.2	✓	✓	✓
k) Coil transient suppression	3.5.7.1	4.11.8.6.1	2.4.5.1		✓	✓
l) Block integrity	3.5.7.2	4.11.8.6.2	2.4.5.2			✓
4. Solderability <u>3/</u>	3.6.2	4.11.4	2.7.2, 2.8	✓	✓	✓
5. Seal	3.6.3	4.11.5	2.1.5	✓	✓	✓
6. Visual inspection, external <u>4/</u>	3.6.18	4.11.1.2	2.1.3, 2.1.4, 2.1.6, 2.2	✓	✓	✓

**Notes to Table 11:**

1/ 100% inspection applies, unless otherwise noted. For 100 % inspection, discard all failed relays.

2/ Test sequence is optional.

3/ Perform on 2 relays from each lot. Failed relays resulting from Room Temperature Electrical Measurements may be used for test.

4/ Physical dimensions and weight shall be measured on two sample units per lot.

**Table 12. Screening and Electrical Measurements. 1/**

Inspection	Requirement in TR-HIREL-1	Test method in TR-HIREL-1	Details and exceptions in this spec	Diode Codes		
				None	D	DD
1. Vibration, sinusoidal	3.6.6	4.11.11.1	2.8	✓	✓	✓
2. Vibration, random (when specified)	3.6.6	4.11.11.2	2.7.2, 2.8	✓	✓	✓
3. Particle impact noise detection (PIND) test (when specified)	3.6.21	4.11.23	2.7.2	✓	✓	✓
4. Internal moisture	3.6.1	4.11.3.1		✓	✓	✓
5. Thermal cycle/Miss test	3.6.19	4.11.3.2				
First four hot/cold cycles:						
a) Coil continuity		4.11.3.2.1		✓	✓	✓
Fifth hot/cold cycle:						
b) High temperature soak		4.11.3.2.1		✓	✓	✓
c) High temperature electrical measurements 2/		4.11.3.2.1				
i. Insulation resistance	3.5.1	4.11.6	2.4.1	✓	✓	✓
ii. Pickup voltage	3.5.3.1	4.11.8.1.1	2.4.3	✓	✓	✓
iii. Dropout voltage	3.5.3.3	4.11.8.1.3	2.4.3	✓	✓	✓
iv. Static contact resistance	3.4.1.1	4.11.8.5.1	2.3.2	✓	✓	✓
v. Operate and release time	3.5.6	4.11.8.4	2.4.4	✓	✓	✓
vi. Operate and release contact bounce time	3.4.2.1	4.11.8.5.2	2.3.3	✓	✓	✓
d) High temperature Miss test	3.6.1	4.11.3.2.1, 4.11.3.2.2		✓	✓	✓
e) Low temperature soak		4.11.3.2.1		✓	✓	✓
f) Low temperature electrical measurements 2/		4.11.3.2.1				✓
i. Pickup voltage	3.5.3.1	4.11.8.1.1	2.4.3	✓	✓	✓
ii. Dropout voltage	3.5.3.3	4.11.8.1.3	2.4.3	✓	✓	✓
iii. Static contact resistance	3.4.1.1	4.11.8.5.1	2.3.2	✓	✓	✓
iv. Operate and release time	3.5.6	4.11.8.4	2.4.4	✓	✓	✓
v. Operate and release contact bounce time	3.4.2.1	4.11.8.5.2	2.3.3	✓	✓	✓

See notes at end of Table.

**Table 12. Screening and Electrical Measurements (cont'd). 1/**

Inspection	Requirement in TR-HIREL-1	Test method in TR-HIREL-1	Details and exceptions in this spec	Diode Codes		
				None	D	DD
7. Thermal cycle/Miss test (cont'd)						
g) Low temperature Miss test	3.6.1	4.11.3.2.1, 4.11.3.2.2		✓	✓	✓
h) Stabilize at room ambient temperature		4.11.3.2.1		✓	✓	✓
i) Room temperature Miss test	3.6.1	4.11.3.2.1, 4.11.3.2.2		✓	✓	✓
8. Room temperature electrical measurements 2/						
a) Coil resistance	3.5.4	4.11.8.2	2.4.3	✓	✓	
b) Coil current	3.5.5	4.11.8.3	2.4.3			✓
c) Insulation resistance	3.5.1	4.11.6	2.4.1	✓	✓	✓
d) Dielectric withstanding voltage (atmospheric pressure)	3.5.2	4.11.7	2.4.2	✓	✓	✓
e) Static contact resistance	3.4.1.1	4.11.8.5.1	2.3.2	✓	✓	✓
f) Pickup voltage	3.5.3.1	4.11.8.1.1	2.4.3	✓	✓	✓
g) Dropout voltage	3.5.3.3	4.11.8.1.3	2.4.3	✓	✓	✓
h) Operate and release time	3.5.6	4.11.8.4	2.4.4	✓	✓	✓
i) Operate and release contact bounce time (when specified)	3.4.2.1	4.11.8.5.2	2.3.3, 2.7.2	✓	✓	✓
j) Operate and release contact stabilization time (when specified)	3.4.2.2	4.11.8.5.3	2.3.4, 2.7.2	✓	✓	✓
k) Coil transient suppression	3.5.7.1	4.11.8.6.1	2.4.5.1		✓	✓
l) Block integrity	3.5.7.2	4.11.8.6.2	2.4.5.2			✓
9. Seal	3.6.3	4.11.5	2.1.5	✓	✓	✓
10. Radiographic inspection	3.6.20	4.11.22		✓	✓	✓
11. Visual inspection, external	3.6.18	4.11.1.2	2.1.3, 2.1.6, 2.2	✓	✓	✓
12. Check for lot failure		4.8		✓	✓	✓

**Notes to Table 12:**

1/ Inspection sample 100 % unless otherwise noted; discard all failed relays.

2/ Test sequence is optional.

3. Ground pin attachment, spacer attachment, lead trimming, or lead solder coating processes may be performed before, during, or after Screening and Electrical Measurements. An electrical inspection, and/or seal test, and/or external visual and mechanical inspection, as applicable, shall follow any of these processes.

**Table 13. Lot Acceptance Test 3. 1/**

Inspection	Requirement in TR-HIREL-1	Test Method in TR-HIREL-1	Details and exceptions in this spec	Diode Codes		
				None	D	DD
1. Room temperature electrical measurements <u>3/</u>						
a) Coil resistance	3.5.4	4.11.8.2	2.4.3	✓	✓	
b) Coil current	3.5.5	4.11.8.3	2.4.3			✓
c) Insulation resistance	3.5.1	4.11.6	2.4.1	✓	✓	✓
d) Dielectric withstanding voltage (atmospheric pressure)	3.5.2	4.11.7	2.4.2	✓	✓	✓
e) Static contact resistance	3.4.1.1	4.11.8.5.1	2.3.2	✓	✓	✓
f) Pickup voltage	3.5.3.1	4.11.8.1.1	2.4.3	✓	✓	✓
g) Dropout voltage	3.5.3.3	4.11.8.1.3	2.4.3	✓	✓	✓
h) Operate and release time	3.5.6	4.11.8.4	2.4.4	✓	✓	✓
i) Operate and release contact bounce time (when specified)	3.4.2.1	4.11.8.5.2	2.3.3, 2.7.2	✓	✓	✓
j) Operate and release contact stabilization time (when specified)	3.4.2.2	4.11.8.5.3	2.3.4, 2.7.2	✓	✓	✓
k) Coil transient suppression	3.5.7.1	4.11.8.6.1	2.4.5.1		✓	✓
l) Block integrity	3.5.7.2	4.11.8.6.2	2.4.5.2			✓
2. Seal	3.6.3	4.11.5	2.1.5	✓	✓	✓
3. Visual inspection, external	3.6.18	4.11.1.2	2.1.3, 2.1.6, 2.2	✓	✓	✓
4. Check for lot failure		4.8		✓	✓	✓
<b>Notes to Table 13:</b>						
<u>1/</u> See TR-HIREL-1, paragraph 4.10.3.3 and 2.7.2 herein.						
<u>2/</u> Test sequence is optional.						

**Table 14. Lot Acceptance Test 2. 1/**

Inspection	Requirement in TR-HIREL-1	Test method in TR-HIREL-1	Details and exceptions in this spec	Diode Codes		
				None	D	DD
<b>Group I</b>			<b>2.7.2</b>			
1. Life <u>1</u> /	3.6.13	4.11.19	2.3.1, 2.7.2	✓	✓	✓
2. Room temperature electrical measurements <u>2</u> /						
a) Coil resistance	3.5.4	4.11.8.2	2.4.3	✓	✓	
b) Coil current	3.5.5	4.11.8.3	2.4.3			✓
c) Insulation resistance	3.5.1	4.11.6	2.4.1	✓	✓	✓
d) Dielectric withstanding voltage (atmospheric pressure)	3.5.2	4.11.7	2.4.2	✓	✓	✓
e) Static contact resistance	3.4.1.1	4.11.8.5.1	2.3.2	✓	✓	✓
f) Pickup voltage	3.5.3.1	4.11.8.1.1	2.4.3	✓	✓	✓
g) Dropout voltage	3.5.3.3	4.11.8.1.3	2.4.3	✓	✓	✓
h) Operate and release time	3.5.6	4.11.8.4	2.4.4	✓	✓	✓
i) Operate and release contact bounce time (when specified)	3.4.2.1	4.11.8.5.2	2.3.3, 2.7.2	✓	✓	✓
j) Operate and release contact stabilization time (when specified)	3.4.2.2	4.11.8.5.3	2.3.4, 2.7.2	✓	✓	✓
k) Coil transient suppression	3.5.7.1	4.11.8.6.1	2.4.5.1		✓	✓
l) Block integrity	3.5.7.2	4.11.8.6.2	2.4.5.2			✓
3. Visual inspection, external <u>3</u> /	3.6.18	4.11.1.2	2.1.3, 2.1.6, 2.2	✓	✓	✓
4. Check for lot failure		4.8		✓	✓	✓

See notes at end of Table.

**Table 14. Lot Acceptance Test 2 (cont'd). 1/**

Inspection	Requirement in TR-HIREL-1	Test method in TR-HIREL-1	Details and exceptions in this spec	Diode Codes		
				None	D	DD
<b>Group II</b>			<b>2.7.2</b>			
1. Intermediate current <u>1/</u>	3.6.14	4.11.14	2.3.1, 2.7.2	✓	✓	✓
2. Room temperature electrical measurements <u>2/</u>						
a) Coil resistance	3.5.4	4.11.8.2	2.4.3	✓	✓	
b) Coil current	3.5.5	4.11.8.3	2.4.3			✓
c) Insulation resistance	3.5.1	4.11.6	2.4.1	✓	✓	✓
d) Dielectric withstanding voltage (atmospheric pressure)	3.5.2	4.11.7	2.4.2	✓	✓	✓
e) Static contact resistance	3.4.1.1	4.11.8.5.1	2.3.2	✓	✓	✓
f) Pickup voltage	3.5.3.1	4.11.8.1.1	2.4.3	✓	✓	✓
g) Dropout voltage	3.5.3.3	4.11.8.1.3	2.4.3	✓	✓	✓
h) Operate and release time	3.5.6	4.11.8.4	2.4.4	✓	✓	✓
i) Operate and release contact bounce time (when specified)	3.4.2.1	4.11.8.5.2	2.3.3, 2.7.2	✓	✓	✓
j) Coil transient suppression	3.5.7.1	4.11.8.6.1	2.4.5.1		✓	✓
k) Block integrity	3.5.7.2	4.11.8.6.2	2.4.5.2			✓
3. Visual inspection, external <u>3/</u>	3.6.18	4.11.1.2	2.1.3, 2.1.6, 2.2	✓	✓	✓
4. Check for lot failure		4.8		✓	✓	✓

See notes at end of Table.

**Table 14. Lot Acceptance Test 2 (cont'd). 1/**

Inspection	Requirement in TR-HIREL-1	Test method in TR-HIREL-1	Details and exceptions in this spec	Diode Codes		
				None	D	DD
<b>Group III</b>			<b>2.7.2</b>			
1. Overload (highest dc resistive load) <u>1/</u>	3.6.12	4.11.18	2.3.1, 2.7.2	✓	✓	✓
2. Room temperature electrical measurements <u>2/</u>						
a) Coil resistance	3.5.4	4.11.8.2	2.4.3	✓	✓	
b) Coil current	3.5.5	4.11.8.3	2.4.3			✓
c) Insulation resistance	3.5.1	4.11.6	2.4.1	✓	✓	✓
d) Dielectric withstanding voltage (atmospheric pressure)	3.5.2	4.11.7	2.4.2	✓	✓	✓
e) Static contact resistance	3.4.1.1	4.11.8.5.1	2.3.2	✓	✓	✓
f) Pickup voltage	3.5.3.1	4.11.8.1.1	2.4.3	✓	✓	✓
g) Dropout voltage	3.5.3.3	4.11.8.1.3	2.4.3	✓	✓	✓
h) Operate and release time	3.5.6	4.11.8.4	2.4.4	✓	✓	✓
i) Operate and release contact bounce time (when specified)	3.4.2.1	4.11.8.5.2	2.3.3, 2.7.2	✓	✓	✓
j) Coil transient suppression	3.5.7.1	4.11.8.6.1	2.4.5.1		✓	✓
k) Block integrity	3.5.7.2	4.11.8.6.2	2.4.5.2			✓
3. Visual Inspection, external <u>3/</u>	3.6.18	4.11.1.2	2.1.3, 2.1.6, 2.2	✓	✓	✓
4. Check for lot failure		4.8		✓	✓	✓

See notes at end of Table.

**Table 14. Lot Acceptance Test 2 (cont'd). 1/**

Inspection	Requirement in TR-HIREL-1	Test method in TR-HIREL-1	Details and exceptions in this spec	Diode Codes		
				None	D	DD
<b>Group IV</b>			<b>2.7.2</b>			
1. Mechanical life <u>1/</u>	3.6.15	4.11.15	2.3.1, 2.7.2	✓	✓	✓
2. Room temperature electrical measurements <u>2/</u>						
a) Coil resistance	3.5.4	4.11.8.2	2.4.3	✓	✓	
b) Coil current	3.5.5	4.11.8.3	2.4.3			✓
c) Insulation resistance	3.5.1	4.11.6	2.4.1	✓	✓	✓
d) Dielectric withstanding voltage (atmospheric pressure)	3.5.2	4.11.7	2.4.2	✓	✓	✓
e) Static contact resistance	3.4.1.1	4.11.8.5.1	2.3.2	✓	✓	✓
f) Pickup voltage	3.5.3.1	4.11.8.1.1	2.4.3	✓	✓	✓
g) Dropout voltage	3.5.3.3	4.11.8.1.3	2.4.3	✓	✓	✓
h) Operate and release time	3.5.6	4.11.8.4	2.4.4	✓	✓	✓
i) Operate and release contact bounce time (when specified)	3.4.2.1	4.11.8.5.2	2.3.3, 2.7.2	✓	✓	✓
j) Operate and release contact stabilization time (when specified)	3.4.2.2	4.11.8.5.3	2.3.4, 2.7.2	✓	✓	✓
k) Coil transient suppression	3.5.7.1	4.11.8.6.1	2.4.5.1		✓	✓
l) Block integrity	3.5.7.2	4.11.8.6.2	2.4.5.2			✓
3. Visual Inspection, external <u>3/</u>	3.6.18	4.11.1.2	2.1.3, 2.1.6, 2.2	✓	✓	✓
4. Check for lot failure		4.8		✓	✓	✓
<b>Notes to Table 14:</b>						
1/ See TR-HIREL-1, paragraph 4.10.3.3 and 2.7.2 herein.						
2/ Test sequence is optional.						
3/ The header glass criteria is not applicable.						
4. Post-life operating characteristics, operate and release time, and contact dynamic characteristics, as applicable, are allowed to have a 10% variance from the initial allowable values.						

**Table 15. Lot Acceptance Test 1. 1/**

Inspection	Requirement in TR-HIREL-1	Test method in TR-HIREL-1	Details and exceptions in this spec	Diode Codes		
				None	D	DD
<b>Group I</b>			<b>2.7.2</b>			
1. Thermal shock	3.6.4	4.11.9		✓	✓	✓
2. Shock (specified pulse)	3.6.5	4.11.10	2.8	✓	✓	✓
3. Vibration (sinusoidal and random)	3.6.6	4.11.11	2.8	✓	✓	✓
4. Terminal strength	3.6.8	4.11.20	2.8	✓	✓	✓
5. Room temperature electrical measurements <u>2</u> /						
a) Coil resistance	3.5.4	4.11.8.2	2.4.3	✓	✓	
b) Coil current	3.5.5	4.11.8.3	2.4.3			✓
c) Insulation resistance	3.5.1	4.11.6	2.4.1	✓	✓	✓
d) Dielectric withstanding voltage (atmospheric pressure)	3.5.2	4.11.7	2.4.2	✓	✓	✓
e) Static contact resistance	3.4.1.1	4.11.8.5.1	2.3.2	✓	✓	✓
f) Pickup voltage	3.5.3.1	4.11.8.1.1	2.4.3	✓	✓	✓
g) Dropout voltage	3.5.3.3	4.11.8.1.3	2.4.3	✓	✓	✓
h) Operate and release time	3.5.6	4.11.8.4	2.4.4	✓	✓	✓
i) Operate and release contact bounce time (when specified)	3.4.2.1	4.11.8.5.2	2.3.3, 2.7.2	✓	✓	✓
j) Operate and release contact stabilization time (when specified)	3.4.2.2	4.11.8.5.3	2.3.4, 2.7.2	✓	✓	✓
k) Coil transient suppression	3.5.7.1	4.11.8.6.1	2.4.5.1		✓	✓
l) Block integrity	3.5.7.2	4.11.8.6.2	2.4.5.2			✓
6. Seal	3.6.3	4.11.5	2.1.5	✓	✓	✓
7. Visual inspection, external <u>3</u> /	3.6.18	4.11.1.2	2.1.3, 2.1.6, 2.2	✓	✓	✓
8. Check for lot failure		4.8		✓	✓	✓

See notes at end of Table.

**Table 15. Lot Acceptance Test 1 (cont'd). 1/**

Inspection	Requirement in TR-HIREL-1	Test method in TR-HIREL-1	Details and exceptions in this spec	Diode Codes		
				None	D	DD
<b>Group II</b>			<b>2.7.2</b>			
1. Coil life	3.6.9	4.11.21	2.8	✓	✓	✓
2. Resistance to solvents	3.6.16	4.11.16	2.8	✓	✓	✓
3. Resistance to soldering heat	3.6.10	4.11.17	2.8	✓	✓	✓
4. Room temperature electrical measurements <u>2</u> /						
a) Coil resistance	3.5.4	4.11.8.2	2.4.3	✓	✓	
b) Coil current	3.5.5	4.11.8.3	2.4.3			✓
c) Insulation resistance	3.5.1	4.11.6	2.4.1	✓	✓	✓
d) Dielectric withstanding voltage (atmospheric pressure)	3.5.2	4.11.7	2.4.2	✓	✓	✓
e) Static contact resistance	3.4.1.1	4.11.8.5.1	2.3.2	✓	✓	✓
f) Pickup voltage	3.5.3.1	4.11.8.1.1	2.4.3	✓	✓	✓
g) Dropout voltage	3.5.3.3	4.11.8.1.3	2.4.3	✓	✓	✓
h) Operate and release time	3.5.6	4.11.8.4	2.4.4	✓	✓	✓
i) Operate and release contact bounce time (when specified)	3.4.2.1	4.11.8.5.2	2.3.3, 2.7.2	✓	✓	✓
j) Operate and release contact stabilization time (when specified)	3.4.2.2	4.11.8.5.3	2.3.4, 2.7.2	✓	✓	✓
k) Coil transient suppression	3.5.7.1	4.11.8.6.1	2.4.5.1		✓	✓
l) Block integrity	3.5.7.2	4.11.8.6.2	2.4.5.2			✓
5. Visual inspection, external <u>3</u> /	3.6.18	4.11.1.2	2.1.3, 2.1.6, 2.2	✓	✓	✓
6. Check for lot failure		4.8		✓	✓	✓

**Notes to Table 15:**

1/ See TR-HIREL-1 paragraph 4.10.3.3 and 2.7.2 herein.

2/ Test sequence is optional.





3/ The header glass criteria is not applicable.

4 Post-life operating characteristics, operate and release time, and contact dynamic characteristics, as applicable, are allowed to have a 10% variance from the initial allowable values.

**5. GENERAL NOTES.**

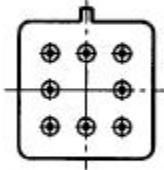
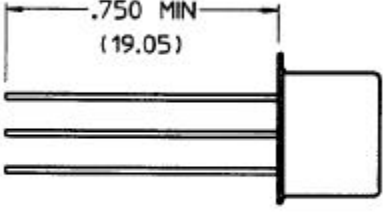
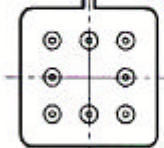
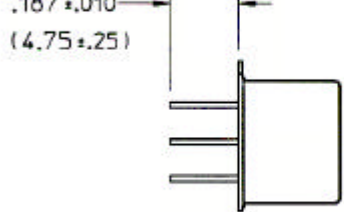
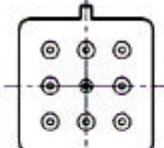
- a) Reverse polarity on the coil terminals of relays supplied with internal diode for coil transient suppression (without polarity reversal protection) will destroy the diode.
- b) When used in applications at high level loads, surge current protection is recommended.

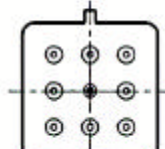
Appendix A. Mounting and Termination Variants.

Mounting	Termination	Configuration	
No Code	No Code G Q	 <p>8 LEADS</p>	 <p>.750 MIN (19.05)</p>
No Code	S SG SQ	 <p>8 LEADS</p>	 <p>.187 ±.010 (4.75 ±.25)</p>
Z	No Code G Q	 <p>9 LEADS</p>	
Z	S SG SQ	 <p>9 LEADS</p>	

Appendix A. Mounting and Termination Variants (Cont'd).

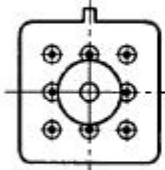
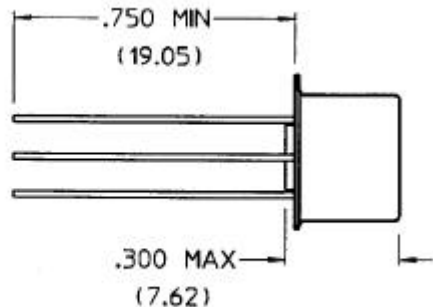
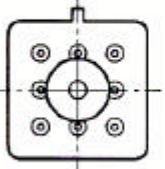
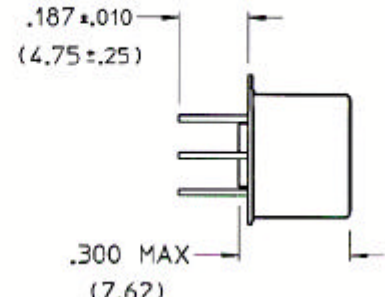
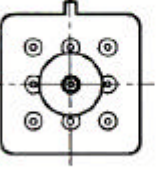
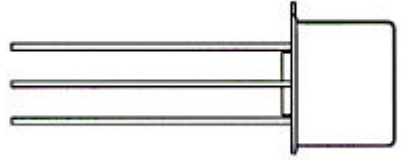
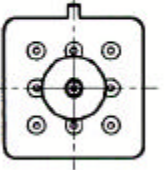
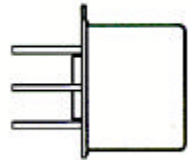
Mounting	Termination	Configuration	
M4	No Code G Q	 <p>8 LEADS</p>	
M4	S SG SQ	 <p>8 LEADS</p>	
ZM4	No Code G Q	 <p>9 LEADS</p>	
ZM4	S SG SQ	 <p>9 LEADS</p>	

**Appendix B. Document Change History.**

<b>Issue or Amendment No.</b>	<b>Date of Issue</b>	<b>Reference and Change Description</b>	<b>Change Notice No.</b>
Issue 1	27 Feb 2001	Official Release	26633